

# Assembly & Installation Instructions

**APPROVED**  
By dwilliams at 8:30 am, Dec 20, 2012

## A WOODEN CLEAT ALTERNATIVE

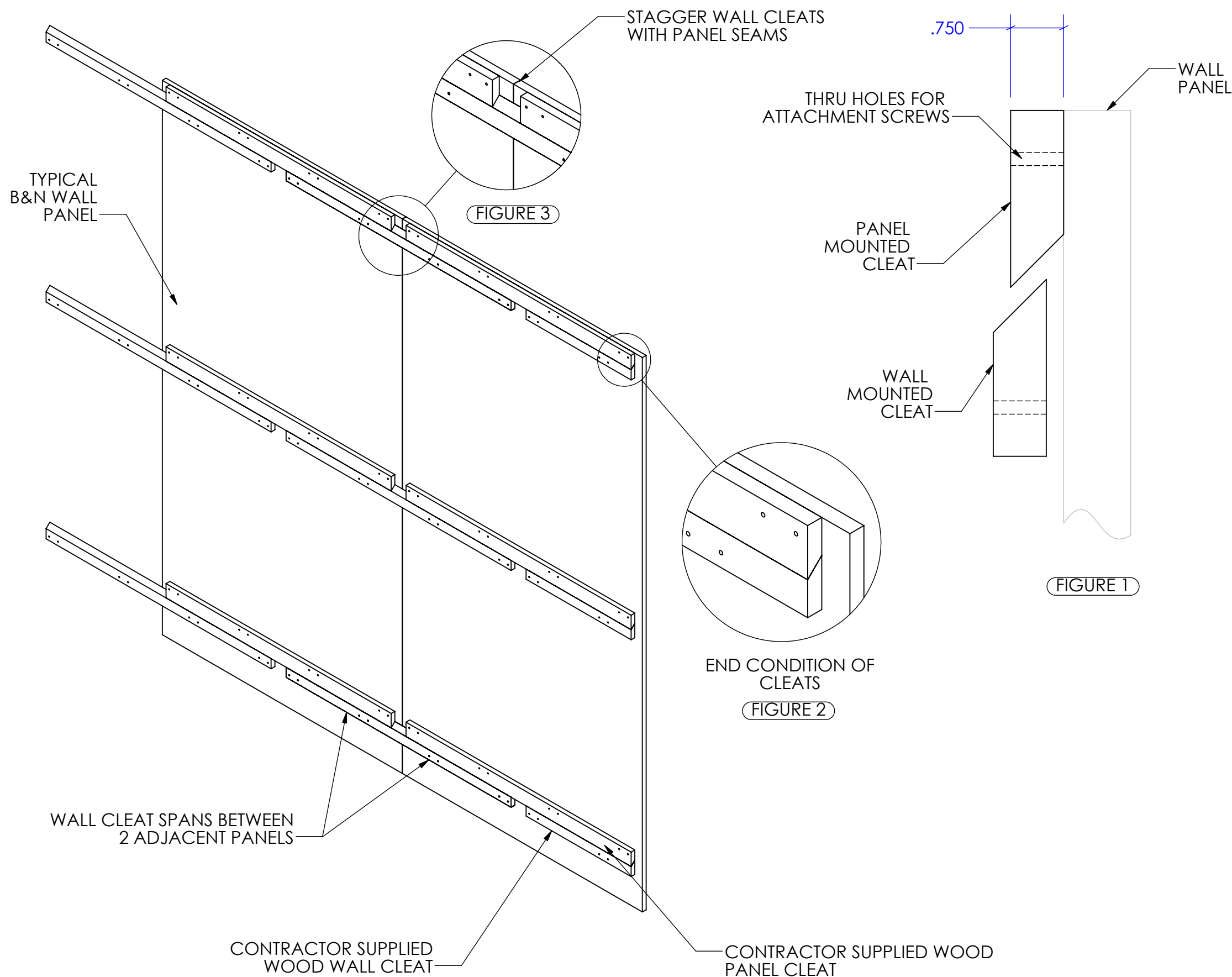

**GENERAL BRIEF:**  
ALL B&N WALL PANELS ARE DESIGNED TO BE MOUNTED TO ONSITE WALLS WITH EITHER ALUMINUM Z-CLIPS OR WOODEN FRENCH CLEATS.

IN ORDER TO KEEP THE PANEL AS FLUSH TO THE WALL AS POSSIBLE, B&N TYPICALLY SUPPLIES 0.25 THICK ALUMINUM Z-CLIPS WITH ALL PANELS. THIS KEEPS PANELS CLOSE TO THE FINISHED WALL, AND ALLOWS FOR EASY REMOVAL AND REPLACEMENT OF PANELS IF NECESSARY.

SHOULD ONSITE CONDITIONS DICTATE THE NEED FOR A THICKER CLEAT, B&N RECOMMENDS THE FOLLOWING STEPS WHEN USING CONTRACTOR SUPPLIED WOODEN (ALSO KNOWN AS FRENCH) CLEATS.

-OUTSIDE CONTRACTOR TO FABRICATE WOOD CLEATS, B&N DOES NOT SUPPLY. CLEATS TO BE CUT IN TYPICAL 45° PROFILE AS SHOWN IN **FIGURE 1**

-WHEN EVALUATING WALL CONDITIONS, BE MINDFUL OF WALL CLEAT ANCHOR LOCATIONS. THE USE OF BLOCKING OR FIR STRIPS IS ADVISABLE.

-ALL B&N PANELS WILL SHIP WITH CLEAT MOUNTING HOLES AND PLASTIC ANCHORS INSERTED IN SEVERAL ROWS ON BACKSIDE OF PANEL.

-PANEL MOUNTED CLEATS TO BE 2.0 INCHES NARROWER THEN THE PANEL IS WIDE, ALLOWING FOR PANEL TO EXTEND BEYOND CLEATS. **FIGURE 2**

-SHOULD MULTIPLE PANELS BE MOUNTED SIDE BY SIDE, IT IS ADVISABLE TO HAVE CLEATS STAGGER WITH THE JOINT LINES BETWEEN PANELS. SEE **FIGURE 3**

-IF FACE ALIGNMENT IS AN ISSUE, SIDEWALLS OF PANELS CAN BE CUT IN THE FIELD TO ACCEPT BEECHWOOD BISCUITS.

-VERTICAL ABUTTING EDGES CAN BE CUT WITH HANDHELD BISCUIT JOINTER. TYPICALLY IT IS NOT NECESSARY TO USE GLUE ON BISCUITS.